



Comprehensive Sign Plan

Snellville, GA

March 14, 2022

Contents

Purpose and Intent.....	2
General The Grove at Towne Center Comprehensive Sign Plan.....	3
Retail Tenant Sign The Grove at Towne Center Comprehensive Sign Plan	4
Submittals and Approvals for Building Mounted Signs.....	6
Tenant Wall Mounted Signs.....	7
Allowable Sign Types	
Plastic Face Channel Letters	
Section Details – Illustration B.....	8
Reverse Channel Letters	
Section Details – Illustration E.....	9
Canopy Mounted Signs	
Illustration F.....	10
Bracket Mounted Signs	
Illustration G	11
Sign Location Plan – Illustration J.....	12
Comprehensive Sign Allowance	
Retail.....	13
Square Footages Calculation – Illustration K.....	14
Allowable Mounting Locations for Fascia Signs - Illustration O & P & Q	15
Allowable Mounting Location for Architectural Entry Signs - Illustration Q	16
Office & Sq. Ft. Calculation.....	17
Residential.....	18
Project Sign Listing.....	19

Purpose and Intent

The purpose and intent of this Comprehensive Sign Plan is to provide the guidelines necessary to achieve a visually coordinated, balanced and appealing sign environment, harmonious with the architecture of the Project, while maintaining provisions for individual graphic expression. The requirements contained herein are intended to provide adequate exposure for the Occupants merchandising and identification while maintaining the overall appearance critical to the success of the Project.

General The Grove at Towne Center Comprehensive Sign Plan

- The Grove at Towne Center Comprehensive Sign Plan sets forth outlines all the Project requirements for signage.
- Occupant signing is expected to enhance and extend the spirit of the architecture for the Project, expression of the high quality of merchandise and services within.
- Graphic Design shall be imaginative, simple and clear. Signage shall be limited to the logo and/or name of the Occupant. Additional icon/imagery for Occupants will be considered (at the sole discretion of the Landlord/Owner) as long as it contributes to the overall identity of Project and meets all applicable requirements of this document and the City of Snellville Signage Masterplan. Occupants are required to retain the services of a professionally trained graphic designer to create their identity and sign program.

Retail Tenant Sign The Grove at Towne Center Comprehensive Sign Plan

1. All Tenants are required to purchase and install their own signs and pay all costs for installation and any electrical service connections (to the Tenant's individually metered service) as required. The storefront and/or blade signage must be installed on or before Tenant opens for business in Tenant space.
2. After first acquiring Owner/Landlord approvals, all Tenants shall be responsible for applying for and acquiring all permits from the City of Snellville prior to installation.
3. To verify compliance with the design intent of The Grove at Towne Center Comprehensive Sign Plan, the Landlord/Owner reserves the right to disapprove all proposed signs and/or graphic treatment governed by The Grove at Towne Center Comprehensive Sign Plan per the Landlord/Owner's interpretation of The Grove at Towne Center Comprehensive sign Plan, and to require revisions of any sign design which the Landlord/Owner judges not in compliance.
4. To verify compliance with the design intent of The Grove at Towne Center Comprehensive Sign Plan, the City of Snellville reserves the right to disapprove all proposed signs and/or graphic treatment governed by The Grove at Towne Center Comprehensive Sign Plan per City of Snellville's interpretation of The Grove at Towne Center Comprehensive sign Plan, and to require revisions of any sign design which the City of Snellville judges not in compliance.
5. All Tenants shall be responsible for removal of its signs upon termination of lease. Damage caused by the installation or removal of the sign and all penetrations appurtenant to the Tenant's sign installation shall be repaired by the Tenant to the satisfaction of the Landlord/Owner within 30 days of the sign removal. If a sign is damaged by a natural event, such as wind, an engineer certified letter is required. This requirement is the same as Georgia building code ground sign wind load requirements. This requirement applies to both ground and fascia signs.
6. No tenant shall erect, install, paint or affix any signs, posters, cards/banners or other advertising medium to upon or above the exterior of the premises of the building, nor on the exterior of the glass surface of the windows and doors, except as stated herein. Tenant shall be held liable and shall bear all costs for removal and/or correction of sign installation and damage to building by signs that do not conform to The Grove at Towne Center Comprehensive Sign Plan or those signs required to be removed by termination of lease. The Landlord/Owner reserves the right to have all non-conforming, non-permitted, non-approved signs by Landlord/Owner removed regardless of state of erection, by Landlord's/Owner's means at sole expense of the Tenant.
7. The Landlord/Owner reserves the right to make periodic changes to The Grove at Towne Center Comprehensive Sign Plan, when approved by the City of Snellville Planning Director. Any changes approved by the Planning Director cannot change the character and/or nature of the proposed The Grove at Towne Center Comprehensive Sign Plan.
8. Tenants with a national logo, service mark or word mark may use their identification mark and type style subject to the criteria contained within this Comprehensive Sign Plan and City of Snellville approval. Tenants without a locally or nationally recognizable logo may choose a type style for approval and may use a logo or mark on their leased space.
9. Sign fabrication and installation shall comply with any applicable building codes, City of Snellville Zoning Ordinance and the National Electrical Code, and all internal and external wiring, lighting, and other electrical devices shall bear the U.L. symbol. It is the Tenant's responsibility to verify that its sign and installation are in accordance with these requirements and have the Jurisdiction's approval.
10. Tenant is responsible for maintaining its sign in a good state of repair including prompt replacement of burned out lighting or damaged components. Tenant shall promptly initiate repairs and make repairs after being notified in writing by Landlord/Owner.

11. All sign fabrication work shall be of excellent quality. All logo images and type styles shall be accurately reproduced. Lettering that approximates type styles shall not be accepted. The Landlord reserves the right to reject any fabrication work deemed to be below standard.
12. Signs must be made of durable rust-inhibited materials that are appropriate and complementary to the building.
13. All formed metal, such as letter forms, shall be fabricated using full-weld construction.
14. All ferrous and non-ferrous metals shall be separated with non-conductive gaskets to prevent electrolysis. In addition to gaskets, stainless steel fasteners shall be used to secure ferrous to non-ferrous metals.
15. Threaded rod or anchor bolts shall be used to mount sign letters which are spaced out from background panel. Angle clips attached to letter sides will not be permitted.
16. Paint colors and finishes must be reviewed and approved by the Landlord. Color coating shall exactly match the color(s) specified on the approved plans.
17. Finished surfaces of metal shall be free from oil-canning and warping. All sign finishes shall be free of dust, orange peel, drips, and runs and shall have a uniform surface conforming to the highest standards of the industry.
18. Reverse channel letters shall be pinned 2" off building fascia. Signs shall have a clear polycarbonate backing and p.k. housings shall be mounted flush to surface of building.
19. All hardware inside open channel letters shall be painted to match interior letter color. Lighting shall be sufficient to make letters read "solid". Exposed lighting is prohibited.
20. All lighting must match the exact specifications of the approved working drawings. Surface brightness of all illuminated materials shall be consistent in all letters and components of the sign. Light leaks will not be permitted.
21. All conduit, raceways, crossovers, wiring, ballast boxes, transformers and other equipment necessary for sign connection shall be concealed.
22. All penetrations into building wall, where required, shall be sealed and waterproofed. Color and finish to match existing wall.
23. Murals that have been approved by the Landlord will be allowed but will require a Special Use Permit.
24. There shall be no signs that are rotating, revolving, flashing, flickering, moving or audible.
25. No sign shall project above or below the allowable sign area. Landlord approved vertical metal signs attached to the building will be allowed.
26. No signs will be allowed that constitute a Traffic Hazard: any building sign which simulates or imitates in size, color, lettering, design of any traffic sign or signal, or which makes use of the words "STOP", "LOOK", "DANGER" or any words or phrases, symbols or characters in such a manner as to interfere with, mislead or confuse traffic.
27. Signs in close proximity to Utility Lines are prohibited, as prescribed by the laws of the jurisdiction.
28. Advertising or promotional signs on parked vehicles are prohibited in the areas identified on Illustration S. This includes signs on or affixed to trucks, automobiles, trailers or other vehicles which advertise, which are not related to the vehicle's lawful activity. This provision does not apply to service and delivery vehicles of Tenants when engaged in regular business activities (i.e. trucks making deliveries to businesses with the Center).

29. Tenants with outdoor seating or dining will be allowed to have umbrellas with the tenant logo affixed to them, subject to Landlord/Owner approval of size, color, quantity and placement.
30. Temporary signs for commercial spaces less than 15,000 SF shall not exceed thirty (32) square feet, or the maximum allowed by the City of Snellville Zoning Ordinance, may be permitted (i.e. for announcing openings and re-openings after remodels) subject to Landlord/Owner approval. These signs are limited to forty-nine days (49) days per calendar year per the City of Snellville *Zoning Ordinance*. This sign will require approval by the City of Snellville Planning Department.
31. Temporary signs for commercial or residential space greater than 15,000 SF and 2 stories or higher, shall not exceed sixty-four (64) square feet, subject to Landlord/Owner approval. These signs are limited to forty-nine days (49) days per calendar year. This sign will require approval by the City of Snellville Planning Department
32. The Landlord/Owner reserves the right to hire an independent electrical engineer at the Tenant's sole expense to inspect the installation of all Tenant's signage and to require Tenant to have any discrepancies and/or code violations corrected at the Tenant's expense.
33. No exposed lighting is permitted on the exterior of the building, including signs, or in the interior of the storefront to highlight the glazing system.
34. Each Tenant will be allowed to display an "A" frame sign on the front, rear or side of the premises. The design and location of the sign must be approved by landlord. A maximum of two (2) signs are allowed and no more than one (1) sign per side.
35. Temporary signs and banners approved by and in a location designated by Owner/Landlord will be allowed on the construction fencing, construction barricades, building or other temporary measures used during the construction of the mixed-use buildings. The banners will not be greater than 6 feet in height and will be wind screen type if installed on the fencing. The banners can identify existing tenants, future tenants, project promotions or advertising, developer, contractor, designers, lenders and other project related entities.
36. Seasonal and event banners no larger than 12 feet by 15 feet can be displayed on the library, mercantile building, and mixed-use buildings. The banners may be changed from time to time at the Owner / City discretion and with approval by both parties. The Owner will provide standard templates to the town for the event banner.
37. Seasonal and event banners no larger than 21 feet by 21 feet will be allowed to be displayed on the parking deck. The banners may be changed from time to time at the City/Owner's discretion and approved by both parties.

Submittals and Approvals for Building Mounted Signs

A copy of The Grove at Towne Center Comprehensive Sign Plan will be provided to future Tenants by the Landlord/Owner.

Prior to sign fabrication and installation, plans for all proposed signage shall be submitted to the Landlord/Owner who will review plans for conformance with The Grove at Towne Center Comprehensive Sign Plan. All plans submitted for approval must conform to requirements of The Grove at Towne Center Comprehensive Sign Plan contained in this Comprehensive Sign Plan. The Landlord/Owner shall have the discretionary authority to deny approval for any submittal which does not comply with this Comprehensive Sign Plan. No sign permit application may be made to the City prior to Landlord/Owner's written approval.

For Landlord/Owner signage approval, such submissions shall include three (3) sets of the following:

- Elevations showing all proposed signs indicating sign type, design, location size and layout of the sign. Drawing to be to scale indicating dimensions, construction details (including materials, colors and lighting specifications) and attachment method(s).
- Section detail of letters and/or sign or logo element(s) showing attachment detail and with electrical specifications.

For City of Snellville signage approval, such submissions shall include all documents required a time of permit. May include, but not limited to, the following:

- Completed Application
- Fee
- Completed Fee Schedule
- Landlord/Owner's approval letter
- All requirements listed on sign application

Following approval of proposed signage by the Landlord/Owner and the City of Snellville, applications for all permits for fabrication and installation by Sign Contractor shall be submitted to the City of Snellville. Fabrication and installation of all signs shall be performed in accordance with the standards and specifications outlined in this Comprehensive Sign Plan, as well as the final approved plans and working drawings. It is the responsibility of the Tenant's sign company to verify all conduit and transformer locations and service access prior to fabrication.

Tenant shall be responsible for all costs for Building Signage and Site Signage panels as follows:

- Design Consultant fees
- Application and permitting fees
- Sign fabrication, related materials and installation fees (including all plan check and inspection costs)
- Signage removal, including repair of any damage to building. It is the Tenant's responsibility to properly patch and repair all holes and paint the patched and repaired area to match the existing color and finish.

Guidelines for individual building mounted sign types are outlined in the following pages.

Tenant Wall Mounted Signs

- A. Plastic Face Channel Letters.** Remote wired or Self-Contained and Reverse Channel Letters. *No raceways permitted.* Maximum filler depth or projection off fascia is to be 12" (see Illustration B for Plastic Face Channel letters and Illustration E for Reverse Channel Letters). Aluminum fillers to be painted with an acrylic polyurethane. Final approval of color to be by Landlord. Welded construction. Acrylic, lexan or polycarbonate letter faces, with or without vinyl graphics. Letters to be internally illuminated with neon tubing using manufacturer's recommended spacing between rows of neon, or LED lighting for maximum illumination. 1" trip cap retainers to match filler color(s).
- B. Reverse Channel Letters.** Remote wired or Self-Contained. Maximum filler depth or projection off of fascia is to be 12". Aluminum fillers and letter faces to be painted with an acrylic polyurethane. Final approval of color to be by Landlord. Welded construction. Lexan or polycarbonate letter backs. Letters to be internally illuminated with neon tubing using manufacturer's recommended spacing between rows of neon for maximum illumination, or LED lighting. See Illustration E.
- C. Non-illuminated 2-dimensional or 3-dimensional individual letters.**
- D. Canopy mounted non-illuminated letters.** See Illustration F.
- E. Externally illuminated letters.** Gooseneck lights allowed for illumination.
- F. Bracket Mounted Signs (Illustration G)**
 - Sign must be stationary and not move.
 - Maximum projection from face of building is 3'-0".
 - Minimum height to bottom of sign is 7'-6".
 - Maximum height to top of sign is not to project above a parapet wall or architectural feature or the limits outlined for sign placement on Illustration O, P, or Q.
 - This shall count as (1) sign with multiple sides.
 - To be mounted only to space of the Tenant.
- G. Vertical Bracket Mounted Signs (Blade Sign) (Illustration H)**
 - **Sign must be stationary and not move.**
 - Maximum projection from face of building is 5'.
 - Minimum height to bottom of sign is 7'-6".
 - Maximum height to top of sign is not to project above a parapet wall or architectural feature or the limits outlined for sign placement on Illustration O, P, or Q.
 - This shall count as (1) sign with multiple sides.
 - To be internally illuminated (if illuminated), no visible neon tubing

Tenant – Plastic Face Channel Letters – Illustration B

Section Details

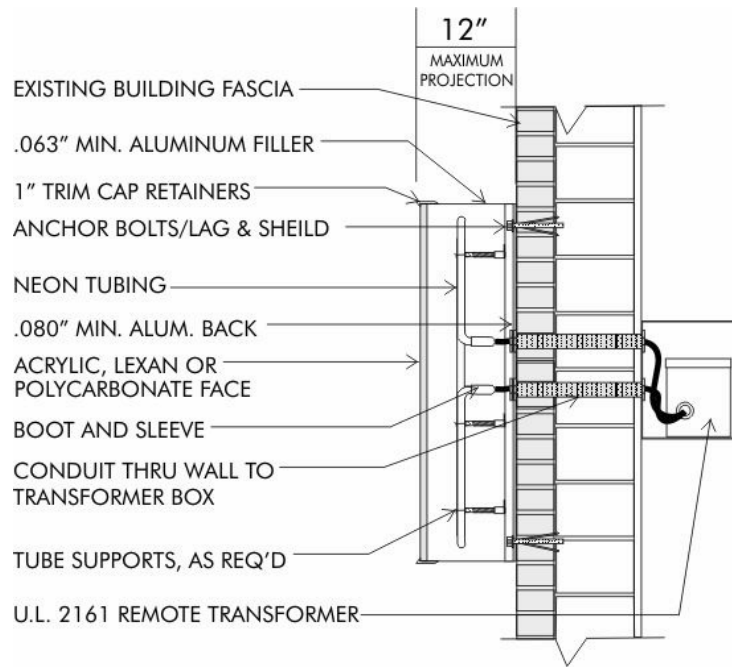

TYPICAL SECTION THRU "REMOTE" LETTERS

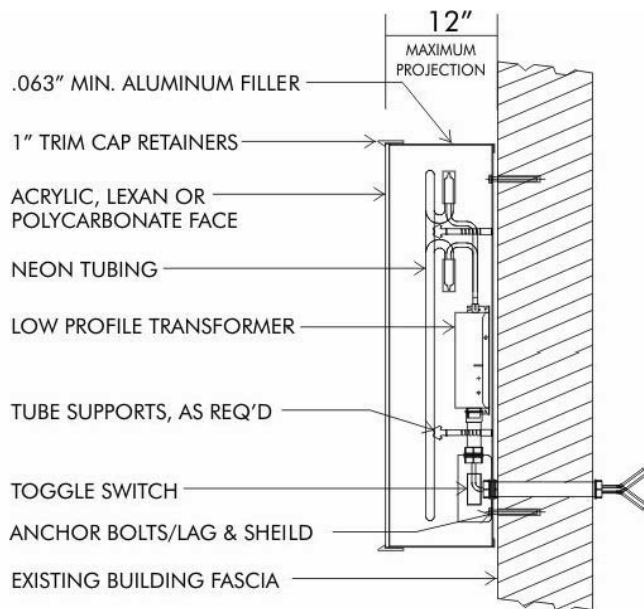

TYPICAL SECTION THRU "SELF CONTAINED" LETTERS

Tenant – Reverse Channel Letters – Illustration E

Section Details

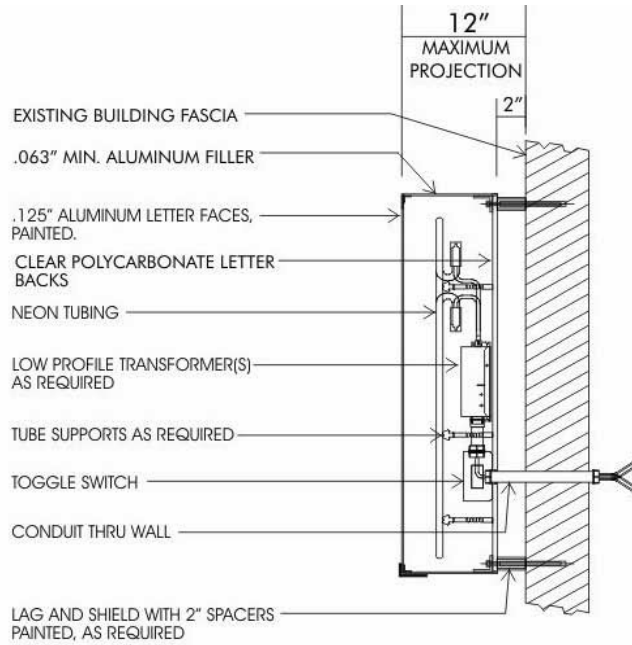

TYPICAL SECTION THRU "REVERSE" CHANNEL LETTERS
SELF-CONTAINED TRANSFORMER

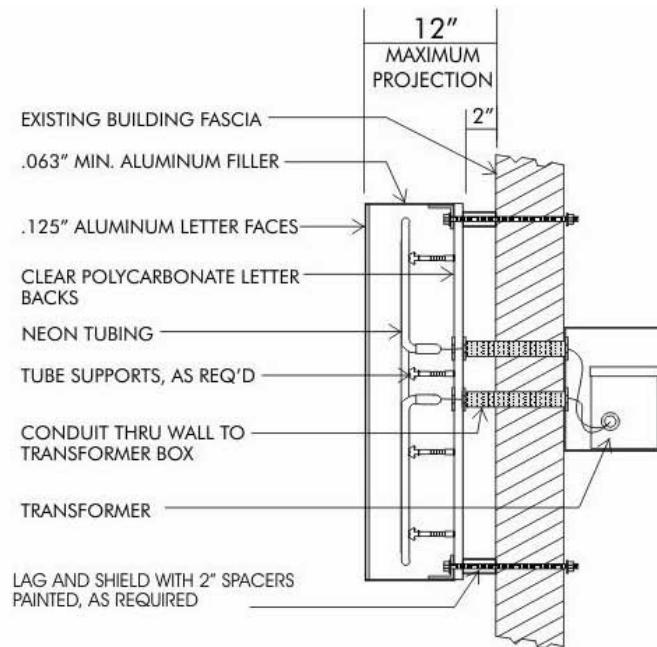

TYPICAL SECTION THRU "REVERSE" CHANNEL LETTERS
REMOTE TRANSFORMER

Tenant – Canopy Mounted Signs – Illustration F

Typical Section Detail – May also include signs on fabric canopies.

* **Note:** square footage to be calculated same as shown on **Illustration C.**

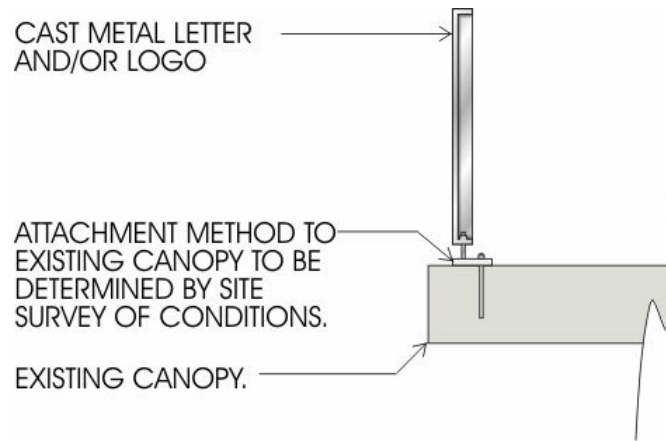

TYPICAL SECTION THRU LETTERS

Tenant – Bracket Mounted Signs – Illustration G

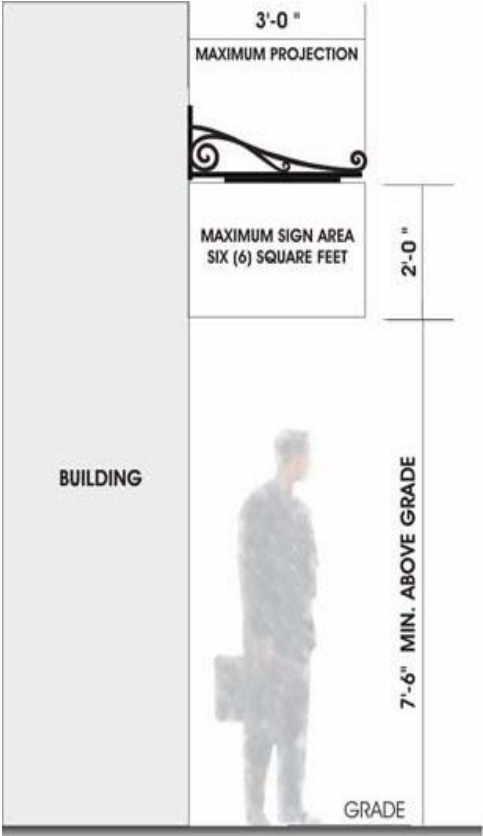

Notes:

- Signs must be “non-swinging”, cannot be hung by chain.
- If projecting more than 12”, must be listed in deviations.
- Minimum height to bottom of sign is 7’-6” above grade.
- Maximum area of sign panel to be six (6) square feet.

Tenant – Vertical Bracket Mounted Signs (Blade Sign) Illustration - H

Primary Blade Sign

Blade sign is located on the Southwest corner of the Tomlin Property. The sign protrudes off the South wall of the corner. Messaging on the sign will be facing East and West along Oak Road.



Key Plan



Location Reference

- 6.1 Primary Multi-Family Blade Sign



SCALE: 1/4" = 1'



MOUNTED ON CENTER OF VERTICAL COLUMN
SCALE: 1/8" = 1'

Comprehensive Sign Allowance

A. RETAIL/OFFICE (Nonresidential) TENANT SIGNAGE

Gross Building Elevation Face Area	Min. Sign Area	Max. Sign Area
1 – 1,000 sf.	36 sf.	5.0% of face areas
1,001 – 2,600 sf.	60 sf.	5.0% of face areas
2,601 - 3,600 sf.	120 sf.	5.0% of face areas
3,601 – 4,500 sf.	140 sf.	5.0% of face areas
Over 4,500 sf.	160 sf.	5.0% of face areas

The gross building elevation face is defined as the area of side of the building from the top finished floor to bottom of parapet. Where more than one main entrance on different sides of the building exists, then both sides may be used to compute total signage allowance for each side. A fascia sign includes: Plastic Face Channel Letters, Reverse Channel Letters, Canopy Mounted, Awning, and Bracket Mounted, depending on which condition Tenant’s space is in (see page 7).

Single Tenant Buildings:

A single tenant building shall be limited to three (3) fascia signs. Each building shall:

- Affix the fascia sign on a wall adjacent to the leased space;
- Limit each fascia sign to separate sides of the building with the exception of the bracket sign which may be placed on the same wall as a reverse channel, or canopy mounted fascia sign; however, two fascia signs will be allowed on the same side of the building provided the side with two fascia signs is the entry side of the building;
- Prohibit plastic face channel or reverse channel on the same side of the building as a canopy mounted fascia sign;
- Limit each sign to no more than five percent (5%) of the building wall or minimal sign area, whichever is greater;
- Place the largest of the signs on the side of the building with the main entrance; and
- Fascia signs shall be mounted on the parapet walls of the building or entry structure such that the top of the sign cannot encroach above the bottom of the cornice or eave of said wall (See illustration O & P for sample locations);
- Fascia Signage that is mounted on a City of Snellville approved architectural element shall be allowed such that no more than 50% of the sign be located above the top of the adjacent parapet. See illustration Q for sample location.

Multi-Tenant Buildings:

A multi-tenant building is permitted to place signs on four sides of the building. Each tenant shall:

- Affix the fascia sign on a wall adjacent to the leased space;
- Have no more than three (3) fascia signs;
- Limit each fascia sign to separate sides of the building with the exception of the bracket sign which may be placed on the same wall as a reverse channel, or canopy mounted fascia sign; however, two fascia signs will be allowed on the same side of the building provided the side with two fascia signs is the entry side of the building;
- Limit each sign to no more than five percent (5%) of the building wall or minimal sign area, whichever is greater
- Place the largest of the signs on the side of the building with the main entrance; and
- Limit the square footage for all signs from the total signage allowed. (See Illustration K for how to measure).
- Fascia signs shall be mounted on the parapet walls of the building or entry structures such that the top of the sign cannot encroach above the bottom of the cornice or eave of said wall (See illustration O & P for sample locations);

- Signage that is mounted on a City of Snellville approved architectural element shall be allowed such that no more than 50% of the sign be located above the top of the adjacent parapet. See illustration Q for sample location.

Illustration K – How to Calculate Total Fascia Signage Square Footage Allowance

EXAMPLE

Square Footage Calculation:

Linear feet of leased building / tenant space = 20' - 0"

Vertical Height of building to top parapet = 24' - 0"

Gross Building Elevation Face = 20' - 0" x 24' - 0" = 480 sf.

Total square footage allowed 36 sf.

**Where 5% of face sign is less than the minimal sign area allowed the greater sign area will be used.*

Illustration O – Limit of Allowable Area for Fascia Sign Mounting on Multi Tenant Building



Illustration P – Limit of Allowable Area for Fascia Sign Mounting on Tenant Entry Feature when Gable Roof Shaped

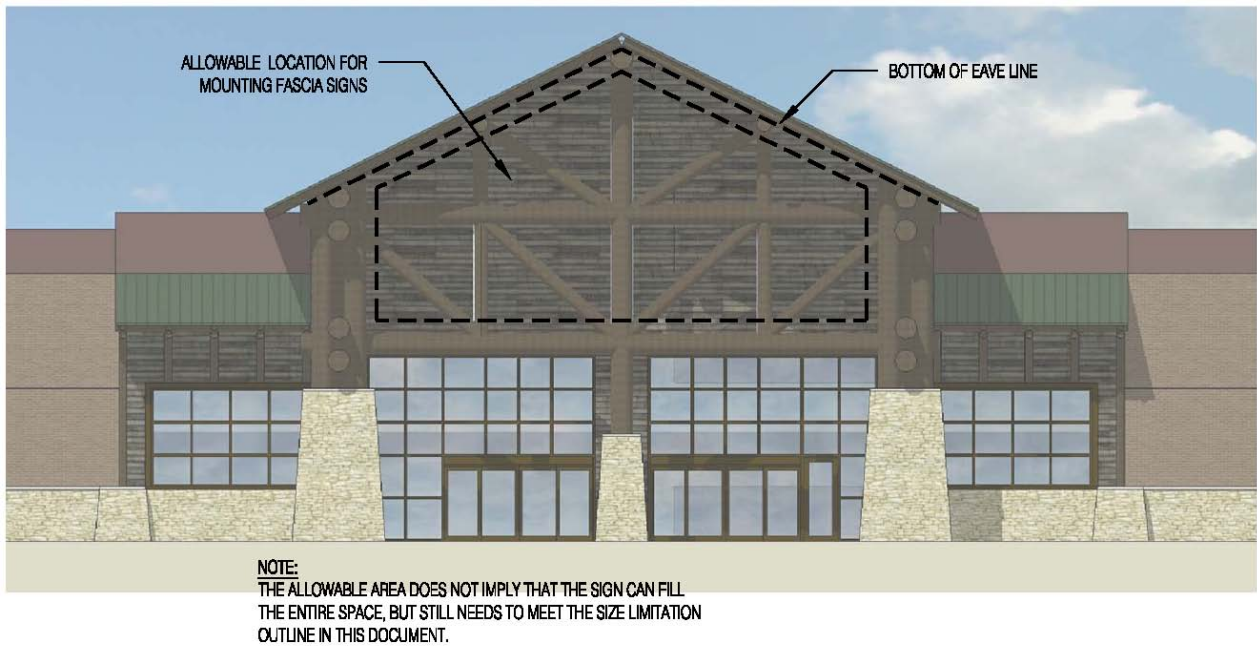
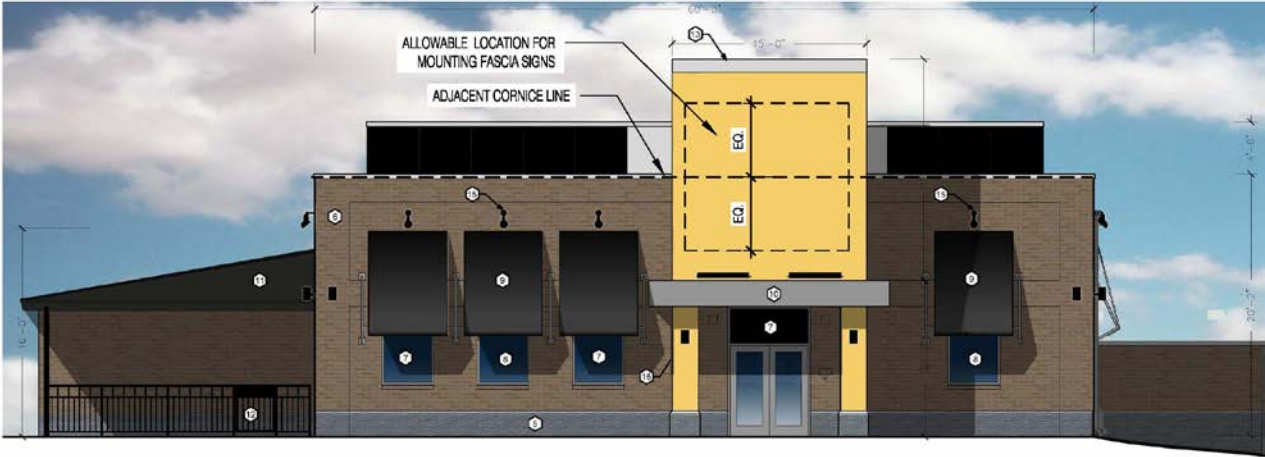

Illustration Q – Limit of Allowable Area for Fascia Sign Mounting on Architectural Entry Feature



NOTE:
THE ALLOWABLE AREA DOES NOT IMPLY THAT THE SIGN CAN FILL THE ENTIRE SPACE, BUT STILL NEEDS TO MEET THE SIZE LIMITATION OUTLINE IN THIS DOCUMENT.

B. RESIDENTIAL SIGNAGE

This guideline is for use in the stand-alone or mixed-use residential signage on building of The Grove at Towne Center.

The building signage can be vertical blade signs, Illustration H, channel letters, canopy letters or reverse channel letters. Residential identification signage will be limited to eighty-five (85) square feet for blade signs with a projection off the building no greater than 5 feet. Other sign types are limited to 150 square feet per side with max being no greater than 5% of the of the face area. Only one identification sign can be placed on each face of the building.

C. Parking Deck Signage

There are no signage limits or guidelines for signage on the parking deck visible from ROW. City and Owner to both agree on final approved signage.

Project Signage Listing

1. **DISPLAY TYPE 1: Primary Entrance Display**
 Located: See sign Location Plan, Illustration M1
 Quantity: (1)
 No greater than 80 square feet (excluding the monument base and supporting structure).
2. **DISPLAY TYPE 2: Secondary Main Entrance Display**
 Located: See sign Location Plan, Illustration M2
 Quantity: (1)
 No greater than 80 square feet (excluding the monument base and supporting structure).
3. **DISPLAY TYPE 3: Street Signs and Posts**
 Various Locations throughout project
 All street signs and posts will comply with the City of Snellville Signage Masterplan.
4. **DISPLAY TYPE 4: Pedestrian Directories**
 Located: See Sign Location Plan, Illustration Directional #1 and Information Kiosk
5. **DISPLAY TYPE 5: Pole Banner**
 Affixed to various poles throughout project.
 All pole banners will comply with the City of Snellville Signage Masterplan.
6. **DISPLAY TYPE 6: Project Logos**
 Located on site amenities such as benches, street signs, umbrellas, and regulatory signs.
 Project ID only.
 Maximum of one (1) square foot, measured with one rectangle, per amenity.

Sign Location Plan – Illustration J

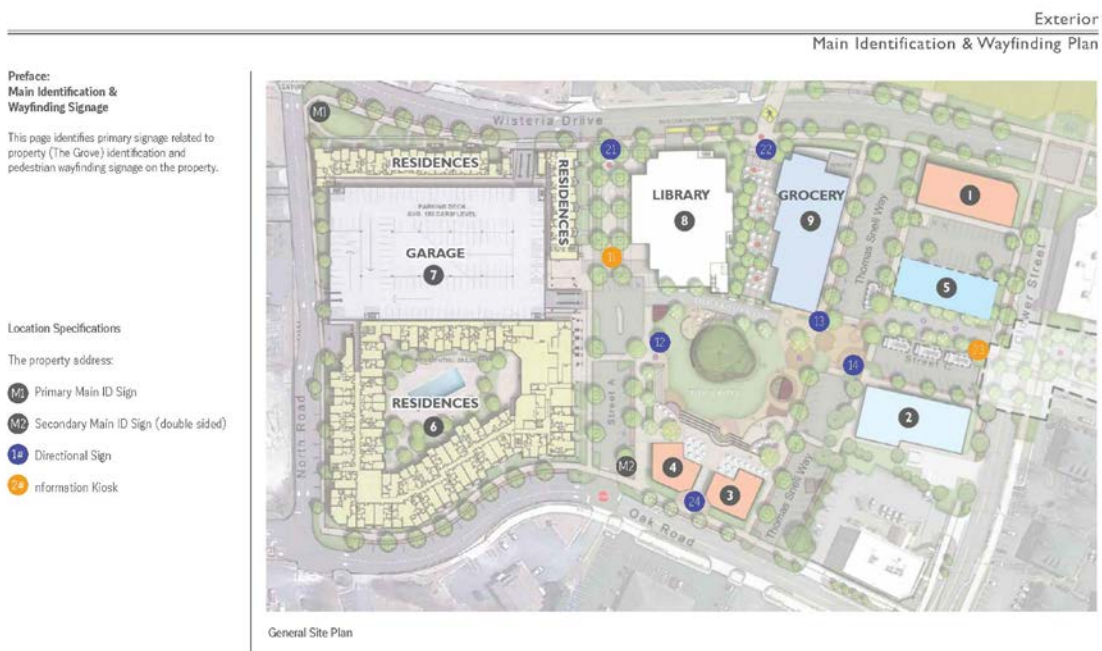

Illustration M1 and M2 – Primary and Secondary ID Sign

Primary Main ID Sign
North Arrival Point

Primary Main ID Sign (M1)

Basic Description
This is the primary arrival point for all residents and visitors.



Location Reference

Primary Main ID Sign



Primary Main ID Sign
South Arrival Point

Secondary Main ID Sign (M2)

Basic Description
This is the primary arrival point for all select residents and visitors.



Location Reference

Secondary Main ID Sign



Illustration Directional #1 and Information Kiosk #2

Series 10 - Directional Signs
Key wayfinding signs that help visitors navigate to a destination within a space.

Series 20 - Information Kiosks
Wayfinding signs that help a visitor view an overall space and locate key features of interest within the space. Often times will contain map artwork and in some instances may utilize an interactive touchscreen.



Location Specifications

- | | |
|----------------|----------------|
| 11 Kiosk | 21 Directional |
| 12 Directional | 22 Directional |
| 13 Directional | 23 Kiosk |
| 14 Directional | 24 Directional |



Illustration T – Exterior Signage



EAST ELEVATION
(WISTERIA DRIVE)



SOUTH ELEVATION
(STREET "A")



NORTH ELEVATION
(NORTH ROAD)



WEST ELEVATION
(OAK ROAD)