

## **CHECKLIST TO PERMIT ROOFED ACCESSORY STRUCTURE**

- **Review Zoning Requirements Information Sheet**
- **Review Accessory Structures Information Sheet**
- **Prepare Site Plan (showing existing and proposed new structures)**
- **Prepare Construction Details**
- **Complete Building Permit Application**
- **Complete Contractor Registration Form**
- **Or Homeowner Affidavit if serving as own contractor**
- **Submit Completed Applications, Forms, Site Plan and Construction Details**
- **Remit \$50 Review Fee Payment (Building Permit Fee Collected Upon Permit Issuance)**

## Lista de verificación para permitir la estructura accesoria techada

- Revisar la hoja de información de requisitos de zonificación
- Revisar la ficha técnica de las estructuras accesorias
- Preparar el plano del sitio que muestre las estructuras existentes y las nuevas propuestas. Se puede dibujar a mano, pero debe ser a escala.
- Preparar detalles de construcción
- Solicitud completa de permiso de construcción
- Completar el formulario de registro de contratista
- Declaración jurada de propietario de vivienda si se desempeña como contratista propio
- Envíe las solicitudes completas, los formularios, el plano del sitio y los detalles de construcción
- Remita el pago de la tarifa de revisión de \$50 (tarifa del permiso de construcción cobrada al momento de la emisión del ipermit)

## Zoning Requirements for Roofed Accessory Structures

A **Roofed Accessory Structure**, also referred to as a shed, storage building, or detached garage is defined as:

*“A small accessory building, such as a garage serving one dwelling unit, shed, gatehouse, gazebo, greenhouse, children’s playhouse and similar accessory use, whether portable or not (except as provided for temporary storage containers), that are subordinate in use and size to the principal use. Excludes all garages except those serving one dwelling unit.”*

And are not the same as an **Accessory Dwelling Unit**, defined as “A small, self-contained dwelling unit located on the same lot as a principal dwelling unit.” Where a dwelling unit is defined as “a single unit providing complete, independent living facilities for one family, including permanent provisions for living, sleeping, eating, cooking, and sanitation.”

Roofed accessory structures are allowed as a limited use in all residential zoning districts, subject to the use standards of UDO Sec. 206-8.26 as follows:

1. **Building Permit Required:** The construction of any roofed accessory structure over twenty (20) sq. ft. in floor area requires a building permit.
2. **Prohibited Locations:** Roofed accessory structures may not be located:
  - a. Within any drainage easement, sewer easement, or other easement as shown on any recorded plat.
  - b. Within any stream buffer or impervious surface buffer.
  - c. Within the Floodplain.
3. **Total Allowed Structures:** No more than three (3) roofed accessory structures are allowed on a single-family detached dwelling lot.
4. **Height Restriction (less than 120 sq. ft.):** Roofed accessory structures under 120 sq. ft. in floor area may not exceed ten (10) feet in height in a residential district.
5. **Exterior Material Requirements & Height Restriction (120 sq. ft. or greater):** Roofed accessory structures 120 sq. ft. or more in floor area must adhere to the following:
  - a. Except for greenhouses, exterior walls of roofed accessory that are accessory to all uses, except single-family detached dwellings, must be finished with brick, stone, cement-based siding, or with materials and colors similar to that of the principal building.
  - b. Except for greenhouses, exterior walls of roofed accessory that are accessory to single-family detached dwellings must be any material listed in sentence a above or factory finished powder-coated metal, except that pre-engineered metal buildings are not allowed.
  - c. Except for greenhouses, roofing materials and roofing colors must match that of the principal building.
  - d. Height may not exceed 20 feet in a residential district.

6. **Maximum Floor Area Requirements:** The maximum allowed cumulative total square footage of all accessory buildings is based on lot size as follows:
- Lots under 10,500 sq. ft.: 500 sq. ft. in floor area, excluding any accessory dwelling unit.
  - Lots 10,501 sq. ft. to 0.99 acre: 750 sq. ft. in floor area, excluding any accessory dwelling unit.
  - Lots over 1 acre: an amount equal to 50% of the floor area of the principal structure, up to a maximum of 2,000 sq. ft. in floor area, excluding any accessory dwelling unit.

**Locations Where Allowed:** UDO Table 201-1.6. contains a listing of the allowed locations for common roofed accessory structures as follows:

**Table 201-1.6. Allowed Locations of Residential District Accessory Uses and Structures (ABRIDGED)**

Accessory Use or Structure A = Allowed in yard " - " = Not allowed in yard	Front Yard	Side Yard (street)	Side Yard (interior)	Rear Yard	Additional Setbacks Standards	Additional Standards
Carport (with metal support posts and metal roof)	--	--	--	--	--	--
Gatehouse	A	A	--	--	--	--
Gazebo	--	--	A	A	See Sec. 201-1.6.B	See Sec. 206-8.26
Greenhouse	--	--	A	A	See Sec. 201-1.6.B	See Sec. 206-8.26
Playground equipment	--	--	--	A	See Sec. 201-1.6.B	See Sec. 206-8.29
Roofed accessory structure, except as shown in this table	--	--	A	A	See Sec. 201-1.6.B	See Sec. 206-8.26

**Setback Requirements:** When shown in Table 201-1.6, accessory uses and structures must observe the following setback requirements adjacent to all lot lines, except when the required building setback is less than the following distances:

- Up to 100 sq. ft. in area: min. 5-foot setback.
- 101 to 300 sq. ft. in area: min. 10-foot setback.
- 301 to 500 sq. ft. in area: min. 15-foot setback.
- Over 500 sq. ft. in area: min. 20-foot setback

# Accessory Structures

## What you need to apply for a building permit:



<input type="checkbox"/>	Site Plan	Page 2
<input type="checkbox"/>	Construction Details	Page 3
<input type="checkbox"/>	Floor Plan	Page 4
<input type="checkbox"/>	Permit Application	



## DID YOU KNOW?

- No permit is required on structures less than 20 square feet
- As “owner-builder” you are the responsible party of record on such a permit. If your work is being performed by a contractor, you may protect yourself from possible liability if the contractor applies for the proper permit in his or her name.
- If you plan to do your own work, with the exception of various trades that you plan to subcontract, the subcontractors must apply for trade permits.
- If you plan to do your own work, including all of the trade work, then you may apply for the permit.
- Frequent practices of unlicensed contractors is to secure “owner-builder” building and trades permits, erroneously implying that the property owner is providing his or her own labor and material personally.
- It would benefit you to hire a licensed contractor to perform the trade work.
- Permits are valid for work to begin within six months.
- Permits expire if no work is performed for longer than 180 days.

## Why Do I need a Permit?

There are many important reasons to obtain building permits and to have inspections performed for your construction project.

### Protects property values

Your home is typically your largest investment. If your construction project does not comply with the building codes, your investment could lose value. If others in your neighborhood make unsafe or substandard changes to their homes, it could lower the resale values for the entire community.

### Saves Money

Homeowners insurance policies may not pay for damages caused by work done without permits and inspections.

### Makes Selling Property Easier

Listing associations require owners to disclose any home improvements or repairs and whether permits were obtained. Many financial institutions will not finance a purchase without proof of a final inspection. If you decide to sell a home or building that has had modifications without a permit, you may be required to tear down the addition, leave it unoccupied or do costly repairs.

### Improves safety

Your permit allows the building department to inspect for potential hazards and unsafe construction. By ensuring your project meets the minimum building code standards of safety, the building department can reduce the risk of fire, structural collapse and other issues that might result in costly repairs, injuries and even death. Inspections complement the contractor’s experience and act as a system of checks and balances that can result in a safer project.

### It’s the Law

Permits are required by Ordinance. Work without a permit may be subject to removal or other costly remedies.

## Tips on hiring contractors

- ◆ Hire only licensed contractors.
- ◆ Get at least 3 bids.
- ◆ Get 3 references, and ask to see a project.
- ◆ Get it in writing, but before you sign the contract, make sure you completely understand.
- ◆ Do not make final payment until you have received a Certificate of Occupancy (CO) and until you are satisfied.
- ◆ **Have the contractor apply for the required permits.**

## What is a Site Plan?

A site plan is a detailed drawing of your property, also known as a survey of your land. These are usually drawn by a land surveyor. The site plan will show the dimensions of your project and its relationship to existing setbacks, easements, utilities, other structures on the property, and distance to your property lines. If your project will require moving any utilities (gas, water, sewer/septic, electric, etc.), show where those meters will be relocated.

### What is REQUIRED for a Permit?

- Provide copies of the SITE PLAN

#### Notes:

1. Structures shall not be permitted to be built over setback lines, easements, or property lines.
2. A survey from a registered land surveyor will be required if your project is located in a protected area.
3. An as-built survey is required if the structure is proposed within 12 inches of a required minimum setback.
4. If your property is on a slope, you may be required to install silt fence to keep the dirt on your property.
5. If you are on a septic tank, you will be required to have approval from the county health department prior to issuance of a permit.
6. If you do not know the location of your utilities, contact the Utility Notification Center. Remember to ask them about the cost of this service.

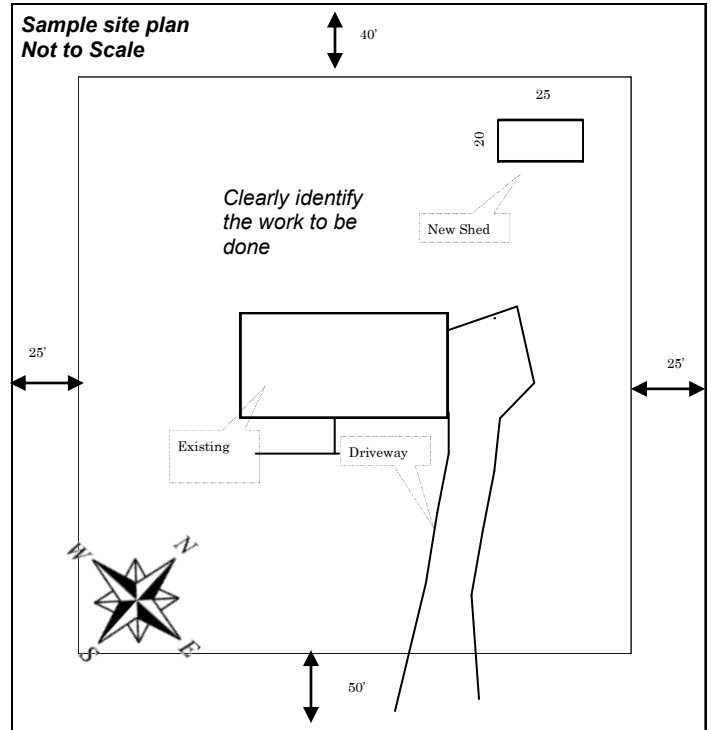

## Inspection Information

### What will the building inspector look at?

#### A typical accessory structure project will require the following inspections:

1. Footings Footing inspections shall be made after trenches are excavated, forms erected, and PRIOR to placing of concrete.
2. Slab Inspection shall be made PRIOR to placing concrete.
3. Frame/Rough Inspection This inspection is made after the roof, all framing, bracing and fasteners are in place.
4. Final Inspection is made AFTER the structure is completed.

The permit technician will let you know your projects' required inspections when the permit is issued.

The purpose of this guide is to assist you in the permitting process. This handout is intended to cover information for a basic plan submittal and typical project under the building codes. It is not intended to cover all circumstances. Depending on the scope and complexity of your project, additional information may be required. Discuss your project with city staff to determine if it is subject to additional requirements.

**City of Snellville - Planning Department**  
**Phone (770) 985-3513 Fax (770) 985-3551**

### How do I schedule a required inspection?

Please call the inspection line (770) 985-3513 and leave all information requested in the message. Inspections are performed in the mornings Monday, Wednesday, and Friday.

# Construction Details

Construction details and specifications help the building department find problems before they occur in the field.

This example shows the types of detail our office will be looking for in your plan submittal.

**In addition to construction details such as these, you will need to submit details on:**

1. Foundation detail
2. Floor Plan



**REMINDER:**

Permits are only issued after plan review. The time required to conduct this review will depend on the completeness of the information we receive in the plans.

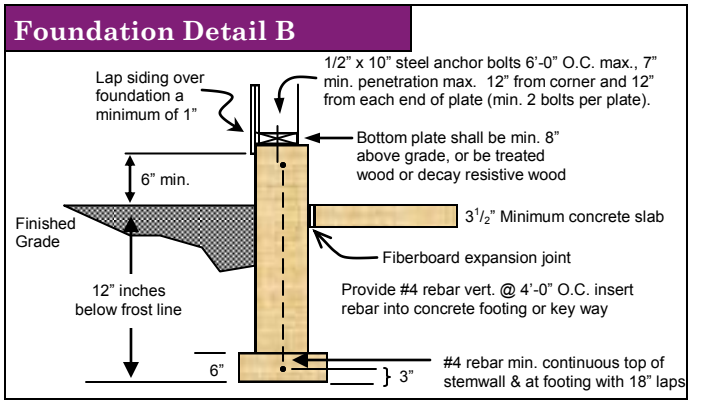
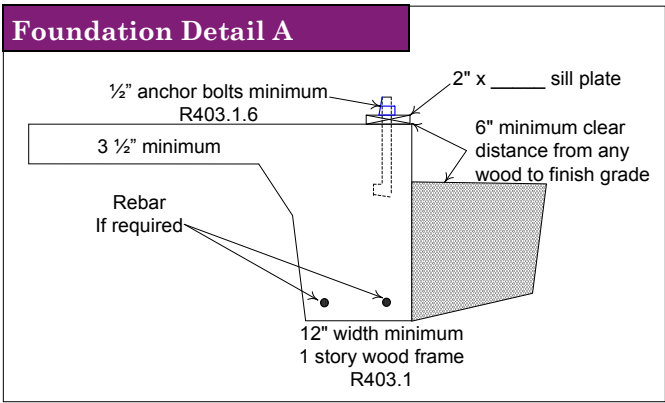
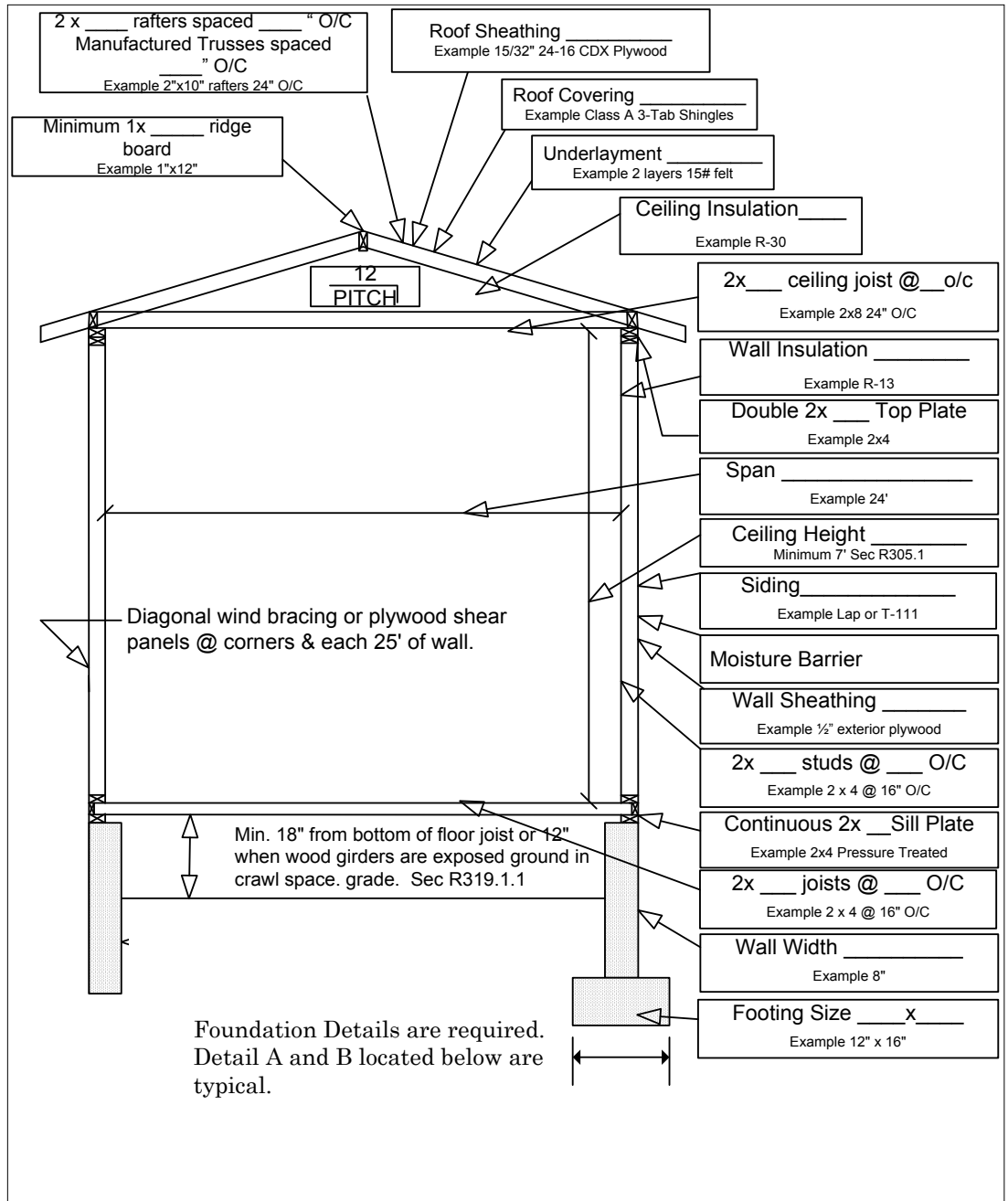

# Floor Plan

The floor plan is used to determine the complexity of the work and to validate the site plan. Floor plans must show any dimensions of the structure and openings.

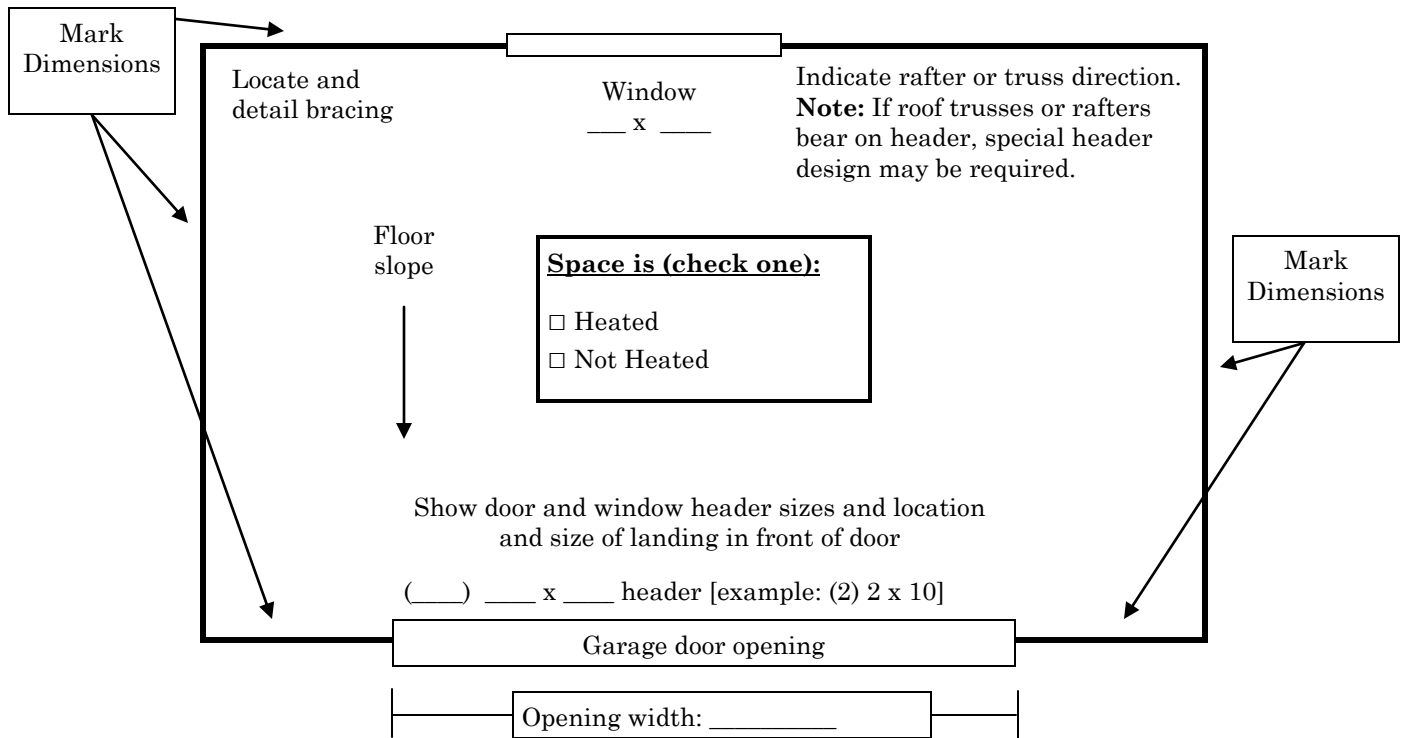

# Braced Wall Panel Detail

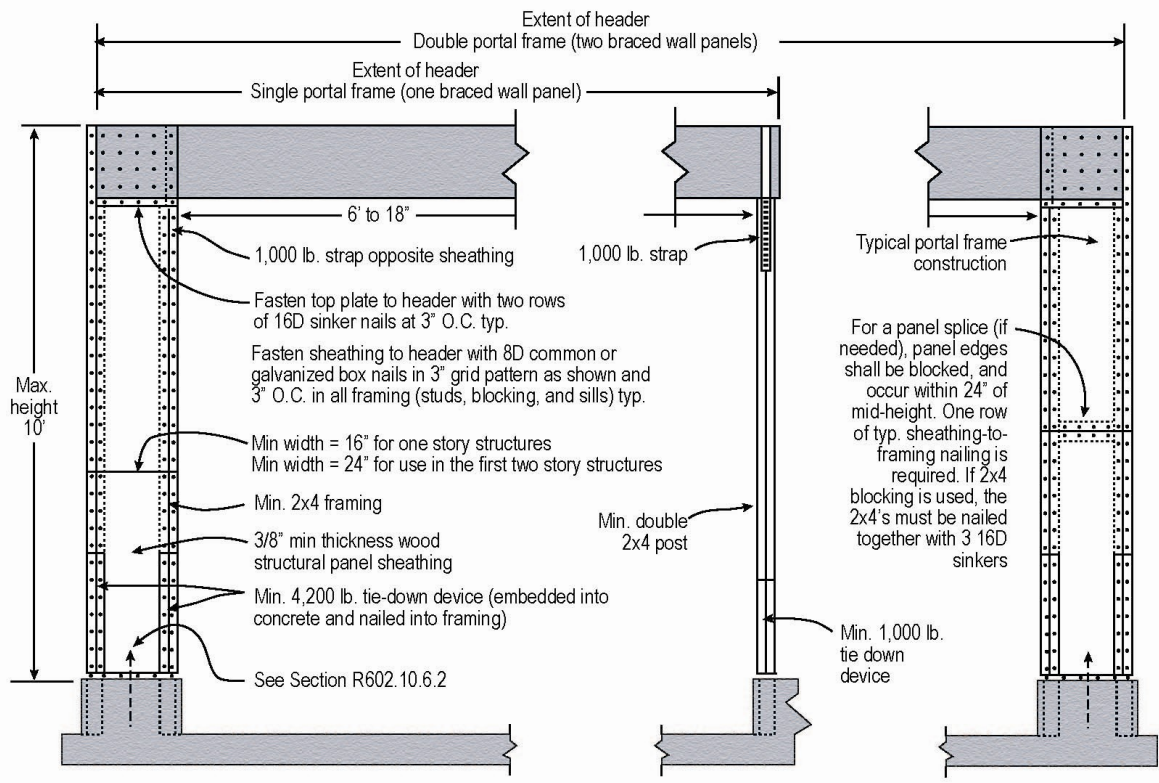





**APPLICATION FOR BUILDING PERMIT  
CITY OF SNELLVILLE, GEORGIA**

FOR CITY USE ONLY

Permit No. \_\_\_\_\_

Date Rcvd: \_\_\_\_\_  
ECC: \_\_\_\_\_

**DESCRIPTION OF WORK (Please mark all that apply)**       RESIDENTIAL       COMMERCIAL

NEW CONSTRUCTION       ADDITION       REPAIR       ACCESSORY STRUCTURE  
 INTERIOR FINISH       ALTERATION       SHELL ONLY       MONUMENT / WALL SIGN

Description of Proposed Construction \_\_\_\_\_

Project Name or Business Location Name \_\_\_\_\_

Job Address \_\_\_\_\_ Lot \_\_\_\_\_ Block \_\_\_\_\_

Project/Subdivision \_\_\_\_\_ Tax Parcel # \_\_\_\_\_ - \_\_\_\_\_ Zoning \_\_\_\_\_

**BUILDING INFORMATION (NEW OR AFFECTED AREA ONLY)** Basement / Slab / Crawl Space (Circle One) \_\_\_\_\_

Stories \_\_\_\_\_ Rooms \_\_\_\_\_ Baths \_\_\_\_\_ Bedrooms \_\_\_\_\_ Heated Sq.Ft. \_\_\_\_\_ Total Sq.Ft. \_\_\_\_\_

Lot Size \_\_\_\_\_ Water Tap # \_\_\_\_\_ Sewer Tap # \_\_\_\_\_ Septic # \_\_\_\_\_ On Septic:  Yes  No

Sprinkler (Protected)     Unprotected (Check One)    Construction Contract Price \$ \_\_\_\_\_

**TYPE OF CONSTRUCTION (NEW CONSTRUCTION ONLY)**  -IA     -IB     -IIA     -IIB     -IIIA     -IIIB     -IV     -VA     -VB

**OCCUPANCY TYPE (GROUP DESCRIPTIONS ON INTERNATIONAL BUILDING CODE LISTING)**

<input type="checkbox"/> -A-1 Assembly, theaters, with stage	<input type="checkbox"/> -E Educational	<input type="checkbox"/> -M Mercantile
<input type="checkbox"/> -A-1 Assembly, theaters, w/o stage	<input type="checkbox"/> -F-1 factory and industrial, moderate hazard	<input type="checkbox"/> -R-1 Residential, hotels
<input type="checkbox"/> -A-2 Assembly, nightclubs	<input type="checkbox"/> -F-2 Factory and industrial, low hazard	<input type="checkbox"/> -R-2 Residential, multiple family
<input type="checkbox"/> -A-2 Assembly, restaurants, bars, banquet halls	<input type="checkbox"/> -H-1 High Hazard, explosives	<input type="checkbox"/> -R-3 Residential, one- and two-family
<input type="checkbox"/> -A-3 Assembly, churches	<input type="checkbox"/> -H234 High Hazard	<input type="checkbox"/> -R-4 Residential, care/assisted living facilities
<input type="checkbox"/> -A-3 Assembly, general, community halls, libraries, museums	<input type="checkbox"/> -H-5 HPM	<input type="checkbox"/> -S-1 Storage, moderate hazard
<input type="checkbox"/> -A-4 Assembly, arenas	<input type="checkbox"/> -I-1 Institutional, supervised environment	<input type="checkbox"/> -S-2 Storage, low hazard
<input type="checkbox"/> -B Business	<input type="checkbox"/> -I-2 Institutional, incapacitated	<input type="checkbox"/> -U Utility, Garages, miscellaneous
	<input type="checkbox"/> -I-3 Institutional, restrained	
	<input type="checkbox"/> -I-4 Institutional, day care facilities	

**OWNER** \_\_\_\_\_ Phone (\_\_\_\_) \_\_\_\_\_

Address \_\_\_\_\_ City/State/Zip \_\_\_\_\_

Fax (\_\_\_\_) \_\_\_\_\_ Cell (\_\_\_\_) \_\_\_\_\_ E-Mail \_\_\_\_\_

**CONTRACTOR** \_\_\_\_\_ Phone (\_\_\_\_) \_\_\_\_\_

Address \_\_\_\_\_ City/State/Zip \_\_\_\_\_

Fax (\_\_\_\_) \_\_\_\_\_ Cell (\_\_\_\_) \_\_\_\_\_ E-Mail \_\_\_\_\_

Business License # \_\_\_\_\_ Issuing Authority \_\_\_\_\_ Exp. Date \_\_\_\_\_

As the contractor, builder, owner or authorized agent, I hereby apply for a permit to erect/alter and use the structure as described herein and/or shown on accompanying plans and specifications. If a plot plan is required, said structure will be located as shown on the plot plan. If the permit is granted, I shall construct same according to the development regulations, ordinances and code of the City of Snellville. Further, I shall be responsible for complying with all subdivision protective covenants (where applicable) and required set backs. I also understand that the structure authorized by the permit shall not be occupied or used until all inspections have been made, all re-inspection fees and fines paid and the Certificate of Occupancy/Completion has been issued by the Department of Planning & Development (and by the Gwinnett County Department of Fire & Emergency Services, when applicable). Applicant must hold a valid Occupational Tax Certificate (AKA "business License") for the type of construction covered by the permit issued. A homeowner is not required to have an Occupational Tax Certificate if building one's own personal home (not more than one home per year). I understand that before any inspections will be made, erosion control measures must be installed and properly maintained daily and licensed subcontractor affidavits must be submitted and accepted. I hereby certify that I am the property owner or the authorized agent of the property owner and that all information contained hereon is true and accurate.

Signature \_\_\_\_\_ Print Name \_\_\_\_\_ Date \_\_\_\_\_



**The City of Snellville**  
Department of Planning & Development  
2342 Oak Road, 2<sup>nd</sup> Floor  
Snellville, GA 30078  
www.snellville.org

(770) 985-3513  
(770) 985-3514  
FAX (770) 985-3551

---

CONTRACTOR REGISTRATION

**PLEASE ATTACHED A COPY OF YOUR CURRENT OCCUPATIONAL  
TAX CERTIFICATE (BUSINESS LICENSE) WITH THIS FORM**

PLEASE MARK THE APPROPRIATE SPACE

GENERAL CONTRACTOR: \_\_\_\_\_ ELECTRICAL: \_\_\_\_\_ H/VAC: \_\_\_\_\_ PLUMBING: \_\_\_\_\_

**COMPANY NAME:** \_\_\_\_\_ **PHONE:** \_\_\_\_\_

**ADDRESS:** \_\_\_\_\_ **FAX:** \_\_\_\_\_

**CITY/STATE/ZIP:** \_\_\_\_\_

**APPLICANT'S NAME:** \_\_\_\_\_ **PHONE:** \_\_\_\_\_

**ADDRESS:** \_\_\_\_\_ **CELL:** \_\_\_\_\_

**CITY/STATE/ZIP:** \_\_\_\_\_

**STATE CARD NO:** \_\_\_\_\_ **CLASSIFICATION:** \_\_\_\_\_

**OCCUPATION TAX CERTIFICATE NO:** \_\_\_\_\_ **EXP. DATE:** \_\_\_\_\_  
(Business License #)

In filing this application for registration, I hereby certify that I am experienced in the classification above and am either familiar with, or will become familiar with all requirements and will abide by all the rules and regulations set forth by the City of Snellville Planning & Development Department.

---

Applicant's Signature

---

Print Name

STATE OF GEORGIA  
COUNTY OF GWINNETT  
CITY OF SNELLVILLE

PERMIT NO. \_\_\_\_\_

PROPERTY ADDRESS: \_\_\_\_\_



### HOME OWNER (DAY LABOR) PERMIT AFFIDAVIT

FOR (Check one):  NEW CONSTRUCTION  
 ALTERATION  
 REPAIR (FIRE OR OTHER HAZARD DAMAGE)

The undersigned hereby applies for special consideration as a property owner desiring to build his/her own residence or accessory structure. In making this request for a "home owner" permit, the undersigned states the following to be true.

- ❖ Applicant intends to reside in the completed structure for at least 12-months from the date of receiving Certificate of Occupancy and does intend to offer it for sale during this 12-month period.
- ❖ Applicant will serve as the general contractor, and accept inherent responsibilities for the work authorized by the issued permit.
- ❖ Applicant agrees to hire properly licensed subcontractors for any work that is further sub-contracted. All electrical, plumbing, heating and air conditioning work shall be done by State licensed contractors.
- ❖ Applicant currently owns property described in permit application. Provide copy of Warranty or Security Deed or property tax bill from the Gwinnett County Tax Commissioner's Office.
- ❖ Applicant agrees to build in accordance with all applicable codes and strictly adhere to the inspection schedule. Undersigned acknowledges that inspections must be performed in an established sequence and that the work done in violation of the codes must be corrected or may be ordered removed.

Applicant acknowledges that he/she is aware that a permit issued under the provisions of the code may be revoked for false statements or misrepresentation as to the material fact in the application on which the permit was based.

Applicant further acknowledges that he/she is aware that any knowingly false statements made in the permit application will subject said applicant to possible prosecution. Georgia Criminal Code, Section 26-2402 (False Swearing) calls for a possible fine of not more than \$1,000.00 or imprisonment for not less than one (1) nor more than five (5) years, or both.

\_\_\_\_\_  
Applicant Printed Name

\_\_\_\_\_  
Signature

\_\_\_\_\_  
Date